

BÜSCHE

A BEAUTIFUL, STRONG MOTORIZED RAIL SYSTEM . . .

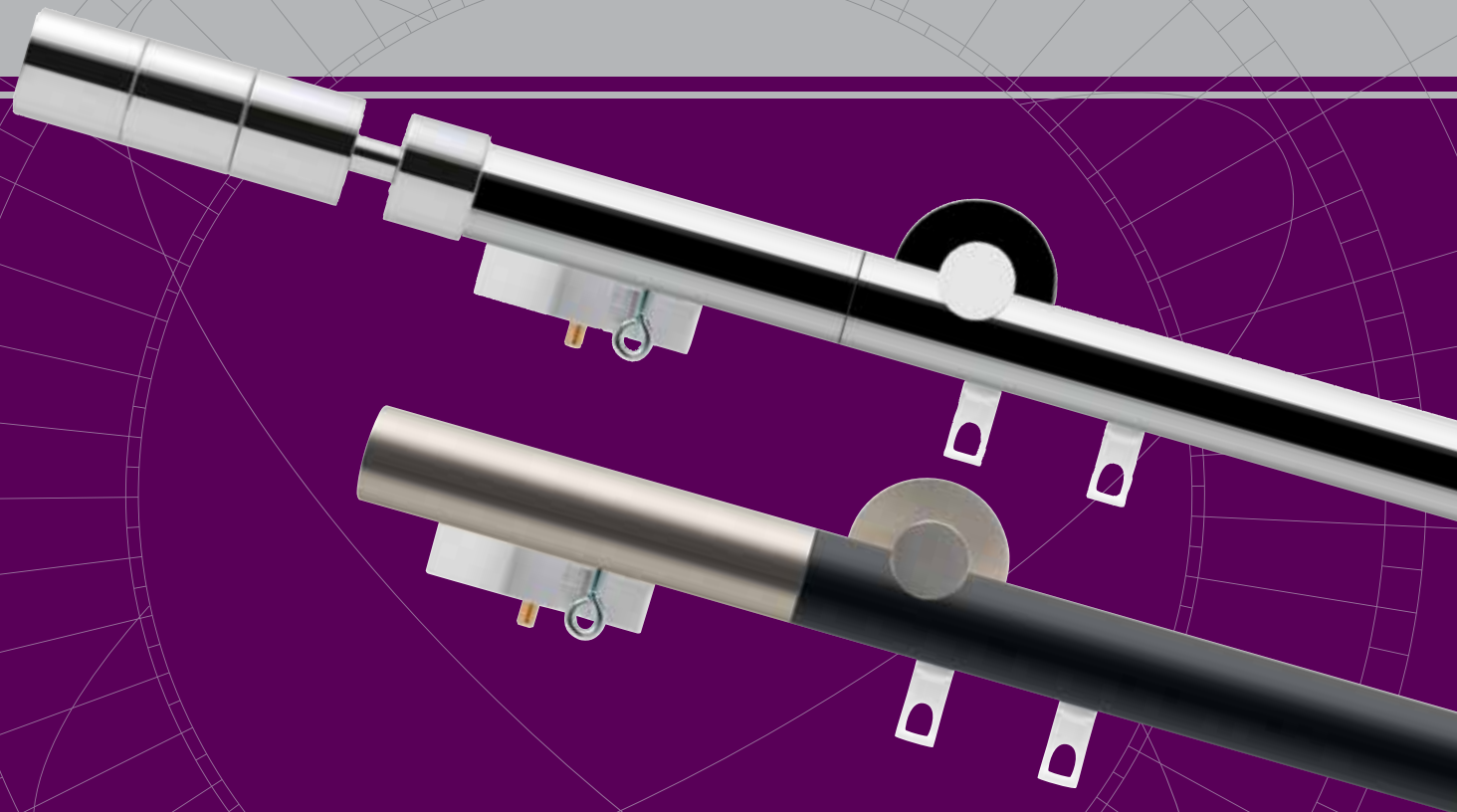

*The Forest Shuttle is compatible
with many automation and
communication systems*



powered by the

Forest[®]
Shuttle

Forest[®]
Eco Shuttle

FOREST
DRAPERY HARDWARE

1 1/8" MOTORIZED DECORATIVE METAL RAIL SETS Recommended maximum weight is 4 lbs. per foot.



22 Polished Chrome Pole with Pescara Finial



22 Polished Chrome Pole with 59 Black End Cap



29 Satin Nickel Pole with Riva Finial



59 Black Pole with 29 Satin Nickel End Cap

AVAILABLE FINISHES XX = finish color

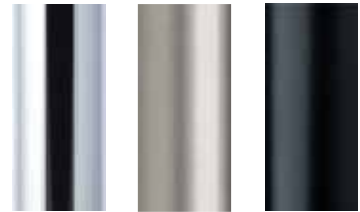

22 Polished Chrome 29 Satin Nickel 59 Black



B809-28-XX
Motorized Decorative Metal Rail, 19' 7"
\$38.56/ft.

ASSEMBLED SYSTEMS INCLUDE:

- Rail cut to your specified width
- Motor, RF receiver (internal on Eco-Shuttle), power supply, and RF remote
- Single Brackets
0'-5' = 2 brackets; 6'-10' = 3 brackets;
11'-15' = 4 brackets; 16'-20' = 5 brackets
- Carriers & Masters
- Please order finials separately
- Additional options are available



COMPONENTS

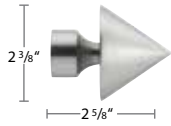

B3356-XX
Riva Finial

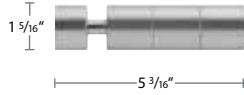

B690-XX
Pescara Finial

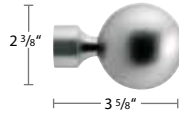

B3362-XX
Alassio Finial



B650-XX
Verona Finial



B610-XX
Napoli Finial

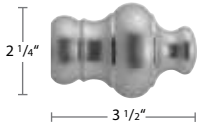

B129328-XX
Alessandria Finial

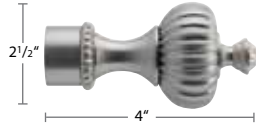

B660-XX
Roma Finial

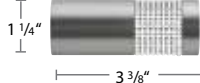

B315-28-XX
Largo Finial

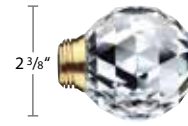

B3389-100
Ardea Finial
use with socket, **B3389/1-XX**

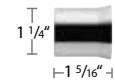

B3389/1-XX
Socket for Ardea Finial

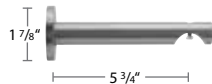

B11670-120-XX
Single Bracket

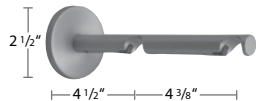

B11672-220-XX
Double Bracket



B11873-50-XX
Ceiling Bracket



B11873-15-XX
Ceiling Bracket. 5/8" Extension



B11592-00
Flush Ceiling Bracket
No finials needed

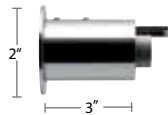

B11682-XX
Recess Bracket
with Return Pulley



B11679-L-XX
Left Motor Pulley



B11679-R-XX
Right Motor Pulley



B11683-L-XX
Left Return Pulley



B11683-R-XX
Right Return Pulley



9012-25
5105501000
Transport Belt
Kevlar reinforced

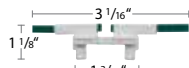

52512-25
5103011500
Transport Belt Connector
Connects belt to master



25008-25
2510101000
Slim Line Contract Klick
shape helps pleats hang straight



Two-Piece Connected Snap Carrier
w/ Square Base in plastic sleeves
use w/ 4 1/4" snap tape
2114-25 60% fullness, 2 5/8" OC
2111-25 80% fullness, 2 3/8" OC
2112-25 100% fullness, 2 1/8" OC
2115-25 120% fullness, 1 7/8" OC



52508-25 Overlap Right
52509-25 Underlap Left
Belt Master Carrier



52508-25a Overlap Right
52509-25a Underlap Left
Belt Master Carrier w/ Snaps



52409-25 Left
52410-25 Right
Butt Master w/ 3 snaps



52927-25
5231000000
Forest Shuttle Motor
24 volt DC



052939-25
5232000000
Forest Eco-Shuttle Motor
24 volt DC

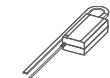

52934-25
24 Volt Power Supply
w/ 16' power cord

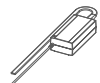

52928-25
5201002001
24 v Power Supply
w/ 7'6" power cord



52932-25
5201001362
RF Multi Receiver



52931-25
5201001460
RF Multi Remote
15 channel w/ holder, includes battery



52933-25
5201001470
RF Wireless Wall Switch
2 channel, includes battery



52930-25
5201001360
RF Multi Receiver
and Wall Switch, includes 18" cable

FOREST MOTORIZED TRACK SYSTEM

Touch Impulse Technology opens or closes drapes with a gentle pull. Integrated emergency control insures manual operation of the drapery in case of power failure. The Shuttle modular motor allows for various control options including RF, wall switch, infrared, building/hotel automation, serial communication, Z-Wave, etc. The Eco Shuttle comes standard with RF control.

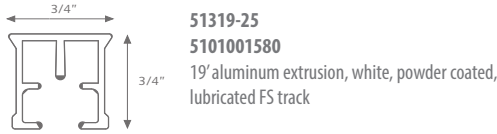

Assembled System includes power supply, RF receiver, and RF remote. Crating and freight are additional.



COMPARISON CHART

	Forest Shuttle	Forest Eco-Shuttle
DIMENSIONS	Motor: 2.76" x 1.97" x 9.25" / Receiver 1.97" x 4.33" x 1.18"	Motor: 2.76" x 1.97" x 7.5" / Receiver Internal
MOUNTING	Wall or Ceiling; Can be spliced	Wall or Ceiling; Can be spliced
MAXIMUM WEIGHT	160 lbs per motor / 120 lbs per motor with curved track	100 lbs per motor / 90 lbs per motor with curved track
TRAVEL SPEED	5.5" per second standard / 7" per second maximum	5.5" per second standard / 7" per second maximum
RECEIVER	External	Internal
TOUCH IMPULSE TECHNOLOGY	✓	✓
EMERGENCY CONTROL	✓	✓
RF COMMUNICATION STANDARD	✓	✓
Z-WAVE COMMUNICATION AVAILABLE	✓	
AUTOMATION SYSTEM COMPATIBLE	✓	w/ dry contacts ✓
10-YEAR WARRANTY	✓	✓

FOREST MOTORIZED SYSTEM COMPONENTS



52927-25
5231000000
Forest Shuttle Motor
24 volt DC



052939-25
5232000000
Forest Eco-Shuttle Motor
24 volt DC



9012-25
5105501000
Transport Belt
Kevlar reinforced



52512-25
5103011500
Transport Belt Connector
Connects belt to master



52903-25
5103011000
Motor Pulley
Connects motor to track



52910-25
5103011100
Return Pulley

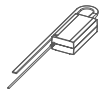

52934-25
5201002003
24 v Power Supply
w/ 16' power cord
\$112.63 ea. 1/box
52928-25
5201002001
24 v Power Supply
w/ 7'6" power cord



52008-25
2510101000
Slim Line Contract Klick
draperies hang to conceal track



52004-25
Low Profile
Ball Bearing Carrier



Two-Piece Connected
Snap w/ Square Base in plastic
sleeve; use with 4 1/4" snap tape
2114-25 60% fullness, 2 5/8" OC
2111-25 80% fullness, 2 3/8" OC
2112-25 100% fullness, 2 1/8" OC
2115-25 120% fullness, 1 7/8" OC

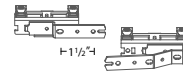

52508-25 Overlap Right
52509-25 Underlap Left
Belt Master Carrier

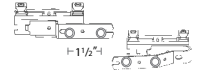

52508-25a Overlap Right
52509-25a Underlap Left
Belt Master Carrier w/ Snap



2552-25
95000000010
6" Extension Arm for Master
Use w/ two one way draws



3003-25
HD Ceiling Bracket
w/ Smart Klick

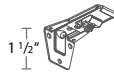

53202-25
3" Smart Klick Wall Bracket
w/ Wide Base
adjusts 3"-4 1/2"

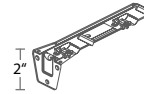

53206-25
6" Smart Klick Double
Wall Bracket w/ Wide Base
adjusts 2 1/2" - 4" & 6"-7 1/2"



3903-25
2518401000
Track Connector
includes Key **3904-00**



52932-25
5201001362
RF Multi Receiver



52931-25
5201001460
RF Multi Remote
15 channel w/ holder
Includes battery



52933-25
5201001470
RF Wireless Wall Switch
2 channel
Includes battery



52930-25
5201001360
RF Multi Receiver
and Wall Switch
Includes 18" cable



The Forest Shuttle is compatible with many Building Automation and Communication systems. Forest Shuttle and Eco Shuttle have the only 10-year warranty on the market!